

**GRAND DUO**

*for violin and piano*

## PERFORMANCE NOTES

### PREMIERE

Completed in 1988, the *Grand Duo* was premiered on July 28, 1988, by Dennis Russell Davies (piano) and Romuald Tecco (violin) at the Cabrillo Music Festival in Aptos, California.

### *Articulation.*

At times (particularly in the “Stampede”), the articulation is deliberately varied in similar passages. Slurring in this edition reflects the composer’s wishes in 1998 as communicated directly to the editor. It follows none of the sources used in preparation of the edition (composer’s autograph, manuscript fair copy, violin performance part, and recording), but rather is a conflation of all these as requested by Harrison. Slurs without a terminal note indicate “LV” (*let vibrare* or *laissez vibrer*): a rest after these incomplete slurs does not imply a release; simply allow the sound to die away gradually.

### *Octave bar instructions.*

The “Stampede” and “Polka” movements require the use of an “octave bar” by the pianist. Such bars, which are simple to construct, allow the playing of octave clusters at rapid tempi. To construct the bar (see diagram) cut a piece of wood (ca.  $\frac{5}{8}$ – $\frac{3}{4}$ " thick and  $1\frac{1}{2}$ " wide) the length of an octave (pianos may vary slightly in size; the bar length will be approximately  $6\frac{1}{2}$ "– $6\frac{5}{8}$ "). Glue, using a strong epoxy-type adhesive, a piece of firm foam approximately  $\frac{1}{2}$ " thick to the bottom of the bar. Then glue two additional shorter pieces of foam ( $\frac{1}{2}$ " thick) at the edges of the device so that they strike the outer notes of the octave to make these notes sound slightly louder than the intervening pitches. To more easily grip the bar, it is helpful to gouge a trough on either side near the top as shown in the diagram. The foam may be covered with felt, which can be stapled to the wood (not shown). The felt will mask the appearance of the bar without distorting the sound significantly.

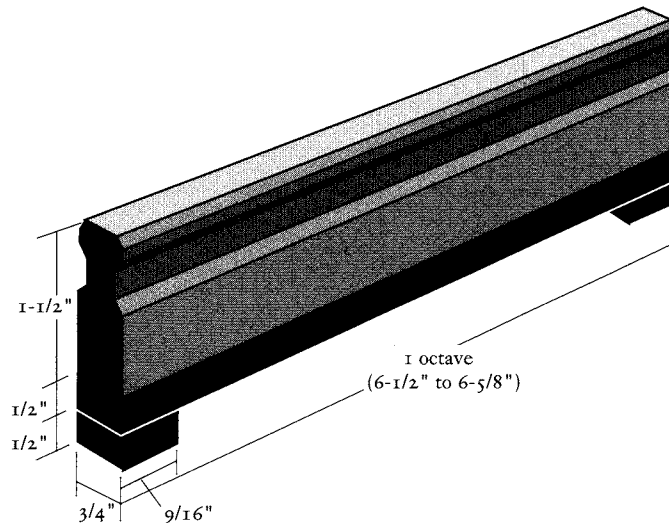

—*diagram by Alan K. Miller;  
used by permission*

### *Recordings.*

MusicMasters 7073-2C (Davies and Tecco). Note: the *Grand Duo* was written for the performers featured on this recording, and the composer supervised this project.

# GRAND DUO

## I. PRELUDE

**Moderato**

Violin

Piano

*ff*

*mp*

*Red.*

5

*ff*

*mf*

*mf*

*Red.*

8

9

(8)

13